

Racor CCV™

Crankcase Ventilation Filter Systems

Installation, Operation, and Parts Information

RACOR®

Parker-Hannifin Corporation
Racor Division
PO Box 3208
3400 Finch Road
Modesto, CA, 95353 USA
(209) 521-7860
(800) 344-3286
FAX (209) 529-3278
<http://www.parker.com/racor>



Contaminated crankcase emissions are a serious problem for diesel engine owners and the environment. These emissions are a result of gas escaping past the piston rings due to high cylinder pressures into the crankcase. In the crankcase, these gases are contaminated with oil mist, water, etc. These contaminated emissions escape through the engine breather into the engine compartment and the engine intake system.

As oil mist builds up on engine components such as radiator cores, turbocharger blades, intercoolers and marine air filters, it attracts dust, grit and other airborne contaminants. The accumulation of particulates on the components affects the efficiency, performance and reliability of the engine.

Crankcase emissions coat the inside of engine rooms, fouling expensive components - increasing cleanup and related costs. These crankcase emissions not only pollute the air and engine room, they contribute to increased engine maintenance costs and can shorten the life of engine components.

The Racor CCV™ Crankcase Ventilation Filter Systems offer an effective solution to reduce contaminated crankcase emissions. The Racor CCV™ system removes crankcase emissions, providing protection for your engine and the environment. The Racor CCV™ system performs the following function(s):

- Keeps engine compartments and components clean.
- Prevents clogging of engine intakes, turbochargers and intercoolers.
- Improves reliability and maintainability of diesel engines.
- More efficient than other products available on the market.
- Reduces environmental pollution from crankcase emissions.
- “Green” element is completely burnable and crushable.
- Reduces smoke and odor in the immediate environment.
- Installed as original equipment by major manufacturers worldwide.

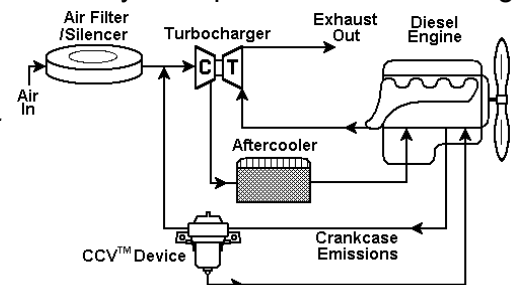

Racor CCV™ System Flow

In the Racor CCV™ filtration system, the contaminated crankcase gases flow from the engine breather into the Racor CCV™ inlet. The contaminated crankcase gases flow underneath a valve diaphragm into the interior of the element. The valve regulates the crankcase to a slight negative pressure to reduce engine weeping and prevent damage to the seals. The contaminated crankcase gases then flow through the filter media. Soot and other contaminants are trapped by the media and the oil is separated from the air. The oil collects at the bottom of the filter housing for return to the engine sump. A check valve is incorporated into the drain return to prevent reverse flow from the oil pan. The filtered gases then flow through the Racor CCV™ outlet. The Racor CCV™ outlet connects with a tap sleeve or marine air filter that returns the filtered gases to the engine intake system. As the filter approaches the need for filter change, a filter service indicator appears at the top of the Racor CCV™.

Racor CCV™ Application Worksheet	Page 2	Racor CCV™ Intake Connector Selection / Installation	Page 6
Racor CCV™ Installation Criteria	Page 3	Service Instructions	Page 7
Racor CCV™ Assemblies	Page 4	Racor CCV™ Service Parts	Pages 8-9
Racor CCV™ Fitting / Hose Kits & Installation	Pages 4-5	Racor CCV™ Application by Manufacturer	Pages 10-15

RACOR CCV™ APPLICATION WORK SHEET

In order to determine the correct Racor CCV™ system for a particular application, certain engine information is required. This form provides an orderly procedure for ordering Racor CCV™ systems. A complete Racor CCV™ engine kit is composed of (1) a Racor CCV™ Assembly, (2) a Fitting / Hose Kit and (3) Air Intake Connector (Tap Sleeve or Marine Air Filter Assembly).

1. SELECT THE RACOR CCV™ ASSEMBLY:

Racor CCV™ application is determined by crankcase flow in CFM. CFM on new engines is low but as the engine wears on, the CFM increases. Select the correct Racor CCV™ model by dividing the engine horsepower output by 40. (See **FIG. 1**)

Example: CAT 3116 – 260HP ÷ 40 = 6.5 CFM, select CCV4500
 CAT 3406 – 525HP ÷ 40 = 13.13 CFM, select CCV6000

MAXIMUM FLOW RATE	
CCV Model	CFM
CCV4500	10
CCV6000	20
CCV8000	40

FIG. 1

2. SELECT A FITTING / HOSE KIT:

Fitting / Hose Kits come with both fittings and enough hose for the inlet and outlet sides of the Racor CCV™ assembly. Racor CCV™ filter units require straight thread o-ring x hose barb fittings available only at Racor. In order to determine the correct application, you need to know the quantity and the outside diameter of engine breather(s) / hose connection. Fitting / Hose Kits are available in various sizes and configurations with components listed (See page 4-5).

3. AIR INTAKE CONNECTOR – SELECT A OR B DEPENDENT UPON APPLICATION

A) TAP SLEEVE – TYPICALLY FOR INDUSTRIAL / MOBILE POWER APPLICATIONS:

Tap sleeves provide for connection of the Racor CCV™ outlet to the engine's air intake. Determine the inside diameter of the hose between the turbo and the air cleaner. This will determine the outside diameter of the tap sleeve required for completion of the installation of your Racor CCV™ system. Verify all dimensions of the tap sleeve before ordering (See page 6).

Example: John Deere #4045T - Hose between turbo & air cleaner is 4" inside diameter. Correct tap sleeve is CCV40100, which is 4" outside diameter.

B) MARINE AIR FILTER ASSEMBLY – FOR MARINE APPLICATIONS:

In order to determine the correct marine air filter application, you will need to know the marine air filter rating (AFR). The customer will need to provide the hose connection to turbo. Choose the correct marine air filter application per the following guideline (see **FIG. 2**). Verify all dimensions of the marine air filter before ordering (See pg. 6).

4 cycle engines: AFR = HP x 2.0
 2 cycle engines: AFR = HP x 2.5

MAXIMUM FLOW RATE	
Marine Air Filter	AFR
AF M408512	800 CFM
AF M501012	1200 CFM
AF M601212	1600 CFM

FIG. 2

NOTE: If AFR is close to maximum capacity of the marine air filter as listed below, use the next size larger.

Example:

DDC 12V92TA DDEC (2 cycle - twin turbo) - 826 hp x 2.5 = 1032.5 AFR per turbo = (2) A FM501012
 1110 hp x 2.5 = 1387.5 AFR per turbo = (2) A FM601212
 CAT 3196 (4 cycle - single turbo) - 660 hp x 2.0 = 1320.0 AFR = (1) A FM601212

In addition, note the dimensions of the marine air filter outlets and the Racor CCV™ connector barb outside diameter from the chart in the Marine Air Filter Kit Installation Section to insure the correct installation for your engine. However, the marine air filters typically correspond with the following CCV™ Models (see **FIG. 3**).

Marine Air Filter	CCV Model
AF M408512	CCV4500
AF M501012	CCV6000
AF M601212	CCV8000

FIG. 3

INSTALLATION CRITERIA

In the Racor CCV™ system, the engine crankcase breather is connected to the inlet of the Racor CCV™ assembly. The Racor CCV™ outlet is connected to the engine's combustion air inlet via air intake connector where filtered blowby gas is recycled through the combustion process. Oil collected in the Racor CCV™ sump is returned to the crankcase through a drain check valve.

- The Racor CCV™ assembly is available in either left-hand or right-hand inlet to facilitate plumbing.
- Hose/fitting kits for Racor CCV™ assemblies are available in various sizes. Refer to the enclosed parts list for ordering assemblies and accessory parts.
- The Racor CCV™ must be mounted upright ($\pm 10^\circ$) and may be directly engine mounted or remote mounted.
- Ensure enough clearance underneath to replace element (see pg. 7). Minimum clearance for the Racor CCV™ is as follows:

CCV4500	CCV6000	CCV8000
2.25"	4.00"	5.00"
- Temperature range of unit is $-40^\circ\text{ F. to }+240^\circ\text{ F.}$ ($-40^\circ\text{ C. to }+116^\circ\text{ C.}$). Avoid mounting locations in areas of extreme temperatures, such as near the exhaust manifold.
- Avoid low spots or valleys in hoses to prevent oil collecting and restricting flow. Keep hoses clear of engine hot spots.
- The Racor CCV™ must be mounted level with or higher than the engine. This is because gravity will allow oil to flow to the engine oil pan.
- Locate an unused dipstick boss or other access to the crankcase. Install the drain check valve as low as possible into the crankcase, preferably above the oil level. Connect the drain hose from the Racor CCV™ sump fitting to the drain check valve with the hose and fittings provided.

CAUTION: DRILLING INTO THE BLOCK OR OIL PAN IS NOT RECOMMENDED. CONSULT WITH YOUR ENGINE MANUFACTURER FOR PROPER HOOKUP OF DRAIN CHECK VALVE.

CAUTION: Check valve must be oriented between vertical and horizontal. (See FIG. 4)

NOTE: VERIFY AIR FILTER INLET RESTRICTION AND CONNECTION

CONTINUOUS DUTY APPLICATIONS – The vertical distance (in inches) from the Racor CCV™ assembly sump drain fitting to the drain check valve must be equal to or greater than the maximum marine air filter inlet restriction (in inches of water (H_2O)). If not, then the accumulated oil in the Racor CCV™ assembly sump will not return to the oil pan properly.

Example: Air filter Inlet restriction is 6.0 inches H_2O . Vertical distance from the sump drain fitting to the drain check valve should be a minimum of 6".

INTERMITTENT DUTY APPLICATIONS - The Racor CCV™ sump capacity will allow for 24 hours of operation and will drain at idle or shutdown.

- For connection of Racor CCV™ assembly to the engine air intake, refer to the table for appropriate size tap sleeve or marine air filter assembly (see pg. 6).

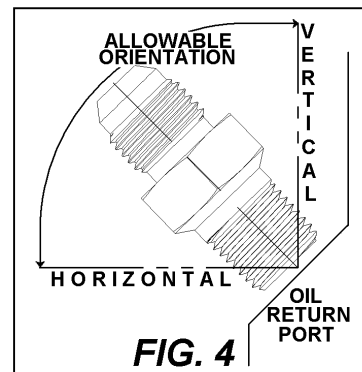

RACOR CCV™ ASSEMBLIES

• CCV4500 SERIES – MAXIMUM FLOW 10 CFM

PART NUMBER	DESCRIPTION	INLET SIDE	MEDIA DENSITY	INLET & OUTLET THREAD SIZE	CHECK VALVE	SWIVEL FITTING (QTY.)	HOSE I.D. SIZE (QTY.)
CCV4500-06L	CCV Assembly	Left	Medium	1-3/16"-12 SAE	¼" MNPT	# 6 JIC (2 pcs.)	3/8" (3 ft.)
CCV4500-06R	CCV Assembly	Right	Medium	1-3/16"-12 SAE	¼" MNPT	# 6 JIC (2 pcs.)	3/8" (3 ft.)
CCV4500-08L	CCV Assembly	Left	High	1-3/16"-12 SAE	¼" MNPT	# 6 JIC (2 pcs.)	3/8" (3 ft.)
CCV4500-08R	CCV Assembly	Right	High	1-3/16"-12 SAE	¼" MNPT	# 6 JIC (2 pcs.)	3/8" (3 ft.)
CCV55248-06	Replacement Element	N/A	Medium	N/A	N/A	N/A	N/A
CCV55248-08	Replacement Element	N/A	High	N/A	N/A	N/A	N/A

• CCV6000 SERIES – MAXIMUM FLOW 20 CFM

PART NUMBER	DESCRIPTION	INLET SIDE	MEDIA DENSITY	INLET & OUTLET THREAD SIZE	CHECK VALVE	SWIVEL FITTING (QTY.)	HOSE I.D. SIZE (QTY.)
CCV6000-06L	CCV Assembly	Left	Medium	1-5/8"-12 SAE	¼" MNPT	# 6 JIC (2 pcs.)	3/8" (3 ft.)
CCV6000-06R	CCV Assembly	Right	Medium	1-5/8"-12 SAE	¼" MNPT	# 6 JIC (2 pcs.)	3/8" (3 ft.)
CCV6000-08L	CCV Assembly	Left	High	1-5/8"-12 SAE	¼" MNPT	# 6 JIC (2 pcs.)	3/8" (3 ft.)
CCV6000-08R	CCV Assembly	Right	High	1-5/8"-12 SAE	¼" MNPT	# 6 JIC (2 pcs.)	3/8" (3 ft.)
CCV55274-06	Replacement Element	N/A	Medium	N/A	N/A	N/A	N/A
CCV55274-08	Replacement Element	N/A	High	N/A	N/A	N/A	N/A

• CCV8000 SERIES – MAXIMUM FLOW 40 CFM

PART NUMBER	DESCRIPTION	INLET SIDE	MEDIA DENSITY	INLET & OUTLET THREAD SIZE	CHECK VALVE	SWIVEL FITTING (QTY.)	HOSE I.D. SIZE (QTY.)
CCV8000-06L	CCV Assembly	Left	Medium	1-7/8"-12 SAE	3/8" MNPT	# 8 JIC (2 pcs.)	½" (3 ft.)
CCV8000-06R	CCV Assembly	Right	Medium	1-7/8"-12 SAE	3/8" MNPT	# 8 JIC (2 pcs.)	½" (3 ft.)
CCV8000-08L	CCV Assembly	Left	High	1-7/8"-12 SAE	3/8" MNPT	# 8 JIC (2 pcs.)	½" (3 ft.)
CCV8000-08R	CCV Assembly	Right	High	1-7/8"-12 SAE	3/8" MNPT	# 8 JIC (2 pcs.)	½" (3 ft.)
CCV55222-06	Replacement Element	N/A	Medium	N/A	N/A	N/A	N/A
CCV55222-08	Replacement Element	N/A	High	N/A	N/A	N/A	N/A

RACOR CCV™ FITTING / HOSE KITS

CCV4500 Series Assemblies		CCV6000 Series Assemblies		CCV8000 Series Assemblies	
Part No.	Description	Part No.	Description	Part No.	Description
CCV55024	(1) ¾" fitting, (1) 1" fitting, (1) ¾" ID x 4 foot long hose, (1) 1" ID x 4 foot long hose, (4) clamps & (4) ties	CCV55046	(2) 1-¼" fitting, (1) 1-¼" ID x 8 foot long hose, (4) clamps & (4) ties	CCV55067	(2) 1-½" fitting, (1) 1-½" ID x 10 foot long hose, (1) bushing reducer, (4) clamps & (4) ties
CCV55025	(2) 1" fitting, (1) 1" ID x 8 foot long hose, (4) clamps & (4) ties	CCV55047	(2) 1-¼" fitting, (1) 1-¼" Tee fitting, (1) 1-¼" ID x 10 foot long hose, (8) clamps & (8) ties	CCV55068	(2) 1-½" fitting, (1) 1-½" Tee fitting, (1) 1-½" ID x 12 foot long hose, (2) bushing reducers, (8) clamps & (8) ties
CCV55037	(1) 1-¼" fitting, (1) 1" fitting, (1) 1-¼" ID x 4 foot long hose, (1) 1" ID x 4 foot long hose, (4) clamps & (4) ties	CCV55048	(2) 1-¼" fitting, (1) 1-½" ID x 4 foot long hose, (1) bushing reducer, (1) 1-¼" ID x 4 foot long hose, (4) clamps & (4) ties	CCV55069	(2) 1-½" fitting, (1) 1-½" ID x 5 foot long hose w/2" cuff, (1) bushing reducer, (1) 1-½" ID x 5 foot long hose, (4) clamps & (4) ties
CCV55038	(1) ¾" fitting, (1) 1" fitting, (1) ¾" ID x 6 foot long hose, (1) ¾" Tee fitting, (1) 1" ID x 4 foot long hose, (8) clamps & (8) ties	CCV55049	(2) 1-¼" fitting, (1) 1-½" ID x 5 foot long hose w/ 2" cuff, (1) bushing reducer, (1) 1-¼" ID x 4 foot long hose, (4) clamps & (4) ties		

All Fitting / Hose Kits include Installation Instructions

RACOR CCV™ FITTING / HOSE KIT INSTALLATION

1. Determine direction of flow (see sketch at right) of the CCV™ Assembly.

2. Install outlet fitting into the outlet port and torque to 50 inch-pounds.

NOTE: CCV4500 takes 1.00" OD Outlet fitting.
CCV6000 takes 1.25" OD Outlet fitting.
CCV8000 takes 1.50" OD Outlet fitting.

3. Install remaining fitting into inlet port and torque to 50 inch-pounds.

4. Select appropriate hose from kit and secure to CCV™ inlet fitting with clamp provided.

5. Locate engine breather connection and cut inlet hose to required length.

CAUTION! When cutting hose, exercise extreme caution. Hose is wire reinforced and protruding sharp edge can result in bodily injury!

6. Secure hose to engine breather connection with clamp provided.

NOTE: If engine breather connection is smaller than hose ID, use the appropriate size rubber bushing on breather.

7. Select appropriate hose from kit and secure to CCV™ outlet fitting with clamp provided.

8. Locate air intake connector fitting barb and cut hose to required length.

CAUTION! When cutting hose, exercise extreme caution. Hose is wire reinforced and protruding sharp edge can result in bodily injury!

9. Secure hose to air intake connector barb with clamp provided.

10. Secure hose(s) to convenient location with ties provided in kit.

NOTE: Avoid low spots or valleys in hoses to prevent oil collecting and restricting flow.
Keep hoses clear of engine hot spots.
Do not kink hose.

11. **FOR ATTACHING MULTIPLE BREATHERS TO ONE CCV™**

a) Use tee fitting provided in kit to branch to both breathers.

b) Extra hose has been provided in kit to accommodate installation of multiple breathers.

c) Verify inlet and outlet distance before cutting any hose.

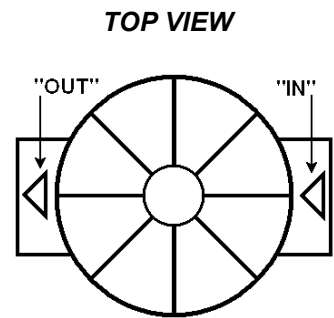

CCV™ AIR INTAKE CONNECTOR SELECTION / INSTALLATION

The air intake connection is made either using a tap sleeve installed between the marine air filter and the turbocharger for industrial or mobile application or using an marine air filter with a Racor CCV™ connector barb for marine applications.

• Tap Sleeve

- Choose the appropriate size tap sleeve according to table and illustration below.
- Locate the area of installation in the hose between the turbo and the marine air filter.
- Cut the hose and insert the tap sleeve.
- Clamp in place on either side. (Customer must supply two (2) clamps per tap sleeve.)
- Attach the hose from the Racor CCV™ outlet to hose barb on the side of the tap sleeve (C) and clamp in place.

Part Number	Outlet Diameter (A)	Length (B)	Hose Barb (C)
CCV30100	3.00	5.00	1.00
CCV40100	4.00	5.00	1.00
CCV50125	5.00	6.00	1.25
CCV60125*	6.00	6.00	1.25
All Tap Sleeves include Installation Instructions			
<i>Note! CCV60125 includes 1-¼" x 1-½" Bushing (connects to 1-½" ID Hose)</i>			

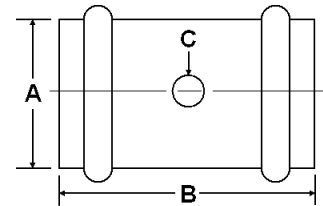

B. Marine Air Filter Assemblies w/ Racor CCV™ Connector;

- Choose the appropriate size marine air filter according to table and illustration below.
- Connect marine air filter to engine intake. (Customer must supply one (1) clamp per marine air filter.)
- Connect hose from outlet of Racor CCV™ to connector (C) on the marine air filter and clamp in place.

NOTE: Marine Air Filter must be firmly attached to a stationary surface. Various applications may require an adapter bracket. This bracket(s) must be supplied or fabricated by customer. Loosen fastener and rotate band clamp to attach to bracket. Fastener(s) are customer supplied.

Marine Air Filter Model	Outlet Diameter (A)	Length (B)	Hose Barb (C)	Filter Outside Diameter (D)
AF M408512	4.00	12.00	1.00	8.50
AF M501012	5.00	12.00	1.00	10.00
AF M601212*	6.00	12.00	1.25	12.00
All Marine Air Filters include Installation Instructions				
<i>Note! AF M601212 includes 1-¼" x 1-½" Bushing (connects to 1-½" ID Hose)</i>				

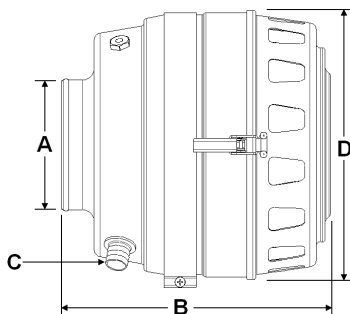

MARINE AIR FILTER SERVICE PARTS	
Marine Air Filter Model	Marine Air Filter Element Part Number
AF M408512	AF M8040
AF M501012	AF M8050
AF M601212	AF M8060

SERVICE INSTRUCTIONS

A. CCV™ REPLACEMENT ELEMENT

The only routine maintenance for the Racor CCV™ system is replacement of the filter media. Typical service life of filter elements for diesel application is 750 hrs. Some variations in this occur, depending on load profile, engine wear condition, flow and aerosol mass concentration of crankcase emissions, soot concentration, etc.

The Racor CCV™ is equipped with a red filter service indicator. In the event the filter becomes plugged prior to the normal service interval, increased pressure against the regulator valve lifts the diaphragm, causing the filter service indicator to appear. This indicates the need to change the filter element. In this case, change the element and re-set the indicator by unscrewing the clear plastic cover and pushing the indicator button down. Replace the cover.

CAUTION: It is recommended all service be performed with the engine shut down. If this is not possible, be careful to avoid moving parts and engine hot spots, as well as electrical connections. Wear safety glasses and hearing protectors. Please note vacuum in the filter canister during engine operation may make it difficult to remove the canister.

- Release latches ⁽¹⁾ which hold the canister ⁽³⁾ to the filter head assembly ⁽²⁾.
- Drop canister ⁽³⁾ down to expose element ⁽⁴⁾. You may notice a slight amount of oil in the bottom. Use caution to avoid spillage.
- Remove the filter element ⁽⁴⁾ by pulling down and dispose of properly. Be sure o-ring ⁽⁵⁾ on top of end cap ⁽⁷⁾ of element and o-ring ⁽⁶⁾ on bottom of head assembly ⁽²⁾ are removed.
- Install new o-ring ⁽⁶⁾ on bottom of head assembly ⁽²⁾.
- Be sure new o-ring ⁽⁵⁾ is on the top end cap of new element and push element up in place, locating the top end cap ⁽⁷⁾ into the hole in the bottom center of the head assembly ⁽²⁾.
- Replace the canister ⁽³⁾ and align latches ⁽¹⁾ in canister ⁽³⁾ with boss on the filter head assembly ⁽²⁾.
- Clamp latches ⁽¹⁾. Snap latches closed. Servicing is complete.

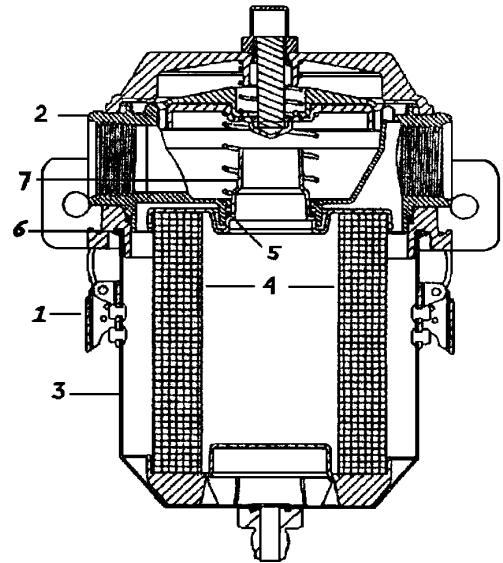

B. MARINE AIR FILTER SERVICING

- Element MUST be serviced at no more than 25 inches of H₂O restriction.

WARNING! Failure to service element can cause loss of engine performance, physical harm and/or fire.

- Release latches holding the marine air filter canister together and remove loose half of canister to expose element.
- Remove the marine air filter element by pulling straight out.
- Clean the marine air filter media by washing it with hot, soapy water.

WARNING! DO NOT use ANY flammable spirits to clean this marine air filter media. Doing so can result in physical harm and/or fire.

- Dry the marine air filter media thoroughly before re-installing element.

CAUTION: Check for cracks and/or damage to element seals. Use of element with degraded seals can result in engine damage.

- Re-oil marine air filter media with suitable air filter oil.
- Re-install marine air filter element.
- Align the latches of both canister halves together and center the replacement element. Push the two halves together so they interlock.
- Snap latches shut.

RACOR CCV™ SERVICE PARTS

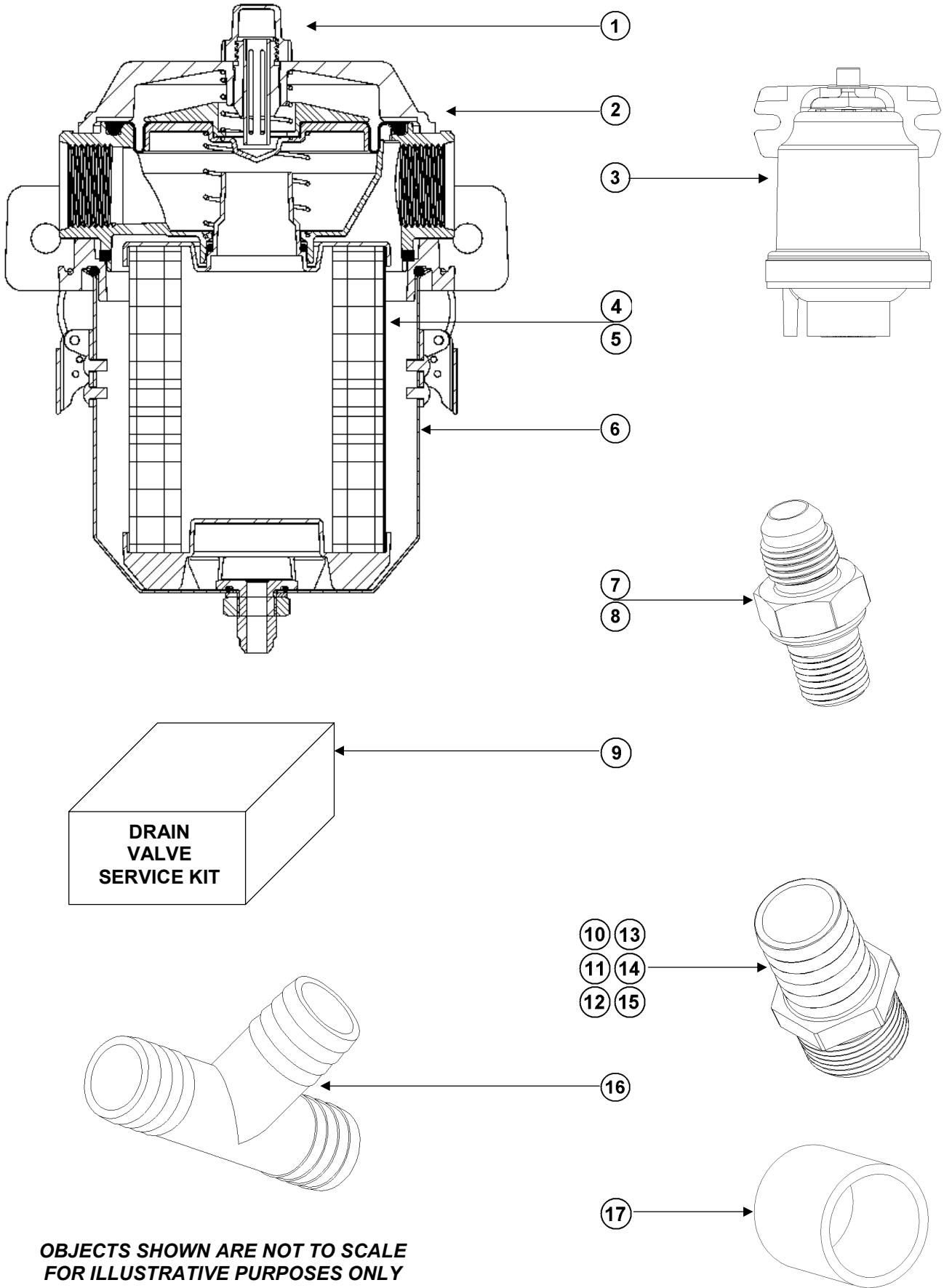

**OBJECTS SHOWN ARE NOT TO SCALE
FOR ILLUSTRATIVE PURPOSES ONLY**

RACOR CCV™ SERVICE PARTS

	CCV4500		CCV6000		CCV8000	
	PART NO.	DESCRIPTION	PART NO.	DESCRIPTION	PART NO.	DESCRIPTION
①	CCV55081	Bypass Indicator Replacement Kit	CCV55081	Bypass Indicator Replacement Kit	CCV55081	Bypass Indicator Replacement Kit
②	CCV55246L	Head Assembly, Left Side Inlet	CCV55272L	Head Assembly, Left Side Inlet	CCV55220L	Head Assembly, Left Side Inlet
	CCV55246R	Head Assembly, Right Side Inlet	CCV55272R	Head Assembly, Right Side Inlet	CCV55220R	Head Assembly, Right Side Inlet
③	CCV55012	"Filter Minder" Remote Crankcase Pressure Indicator	CCV55012	"Filter Minder" Remote Crankcase Pressure Indicator	CCV55012	"Filter Minder" Remote Crankcase Pressure Indicator
④	CCV55248-06	Replacement Element, Medium Density Media	CCV55274-06	Replacement Element, Medium Density Media	CCV55222-06	Replacement Element, Medium Density Media
⑤	CCV55248-08	Replacement Element, High Density Media	CCV55274-08	Replacement Element, High Density Media	CCV55222-08	Replacement Element, High Density Media
⑥	CCV55249	Can Assembly	CCV55275	Can Assembly	CCV55223	Can Assembly
⑦	CCV55279	¼" MNPT Drain Check Valve	CCV55279	¼" MNPT Drain Check Valve	CCV55080	3/8" MNPT Drain Check Valve
⑧	CCV55245	#4 SAE Drain Check Valve	CCV55245	#4 SAE Drain Check Valve	CCV55288	#8 SAE Drain Check Valve
⑨	CCV55022	Drain Kit – contains (2) swivel fittings (P/N 955-W6-H6), ¼" MNPT check valve, 3 feet of 3/8" ID hose & instructions	CCV55022	Drain Kit – contains (2) swivel fittings (P/N 955-W6-H6), ¼" MNPT check valve, 3 feet of 3/8" ID hose & instructions	CCV55071	Drain Kit – contains (2) swivel fittings (P/N 955-W8-H8), 3/8" MNPT check valve, 3 feet of ½" ID hose & instructions
⑩	CCV55250	1" OD Hose Barb x 1-3/16" Straight Thread O-Ring Fitting	NOT AVAILABLE ON THIS MODEL		NOT AVAILABLE ON THIS MODEL	
⑪	CCV55251	¾" OD Hose Barb x 1-3/16" Straight Thread O-Ring Fitting	NOT AVAILABLE ON THIS MODEL		NOT AVAILABLE ON THIS MODEL	
⑫	CCV55280	1-¼" OD Hose Barb x 1-3/16" Straight Thread O-Ring Fitting	NOT AVAILABLE ON THIS MODEL		NOT AVAILABLE ON THIS MODEL	
⑬	NOT AVAILABLE ON THIS MODEL		CCV55268	1-¼" OD Hose Barb x 1-5/8" Straight Thread O-Ring Fitting	NOT AVAILABLE ON THIS MODEL	
⑭	NOT AVAILABLE ON THIS MODEL		CCV55267	1-½" OD Hose Barb x 1-5/8" Straight Thread O-Ring Fitting	NOT AVAILABLE ON THIS MODEL	
⑮	NOT AVAILABLE ON THIS MODEL		NOT AVAILABLE ON THIS MODEL		CCV55218	1-½" OD Hose Barb x 1-7/8" Straight Thread O-Ring Fitting
⑯	CCV55039	¾" x ¾" x ¾" OD Hose Barb Tee Fitting	CCV 55040	1-¼" x 1-¼" x 1-¼" OD Hose Barb Tee Fitting	CCV55041	1-½" x 1-½" x 1-½" OD Hose Barb Tee Fitting
⑰	NOT AVAILABLE ON THIS MODEL		CCV55020	1-½" x 1-¼" Bushing Reducer	CCV55020	1-½" x 1-¼" Bushing Reducer

RACOR CCV™ APPLICATION BY ENGINE MANUFACTURER

CATERPILLAR

NOTE: Most engines come with elephant-ear air cleaners. Air intake configurations vary considerably and customer should verify outside diameter size of turbo inlet and ability to use tap sleeves or marine air filters. If not, customer can weld a fitting to the clean side of filter element on the back of the housing. Always verify outside diameter size of breathers for hose applications.

Industrial/Mobile Power Applications

ENGINE MODEL NO.	QTY.	P/N	DESCRIPTION
3208 (2 breathers)	1	CCV4500-08L (or R)	Filter Unit
	1	CCV55038	Fitting/ hose kit
	1	CCV40100	Tap Sleeve
3054, 3056 *	1	CCV4500-08L (or R)	Filter Unit
	1	CCV55024	Fitting / Hose Kit
	1	AF M408512	Marine Air Filter
3116, 3304, 3306 3126	1	CCV4500-08L (or R)	Filter Unit
	1	CCV55037	Fitting / Hose Kit
	1	CCV40100	Tap Sleeve
3406, D343	1	CCV6000-08L (or R)	Filter Unit
	1	CCV55046	Fitting / Hose Kit
	1	CCV60125	Tap Sleeve
3408, 3176	1	CCV6000-08L (or R)	Filter Unit
	1	CCV55047	Fitting/hose kit
	1	CCV60125	Tap Sleeve
3412 (2 breathers)	1	CCV6000-08L	Filter Unit
	1	CCV6000-08R	Filter Unit
	2	CCV55046	Fitting / Hose Kits
	Customer to provide connection to air intake		
3412 (High output, 4 breathers)	1	CCV6000-08L	Filter Unit
	1	CCV6000-08R	Filter Unit
	2	CCV55047	Fitting / Hose Kits
	Customer to provide connection to air intake		
3508 - Single turbo	1	CCV8000-08L (or R)	Filter Unit
	1	CCV55069	Fitting / Hose Kit
	Customer to provide connection to air intake		
3508 - Twin turbo D379, D398, D399	1	CCV6000-08L	Filter Unit
	1	CCV6000-08R	Filter Unit
	2	CCV55049	Fitting / Hose Kits
	Customer to provide connection to air intake		
3512, 3516 D398, D399	1	CCV8000-08L	Filter Unit
	1	CCV8000-08R	Filter Unit
	2	CCV55069	Fitting / Hose Kits
	Customer to provide connection to air intake		
3606	3	CCV8000-08L (or R)	Filter Unit
	3	CCV55069	Fitting / Hose Kits
	Customer to provide connection to air intake		
3612, 3616	2	CCV8000-08L	Filter Units
	2	CCV8000-08R	Filter Units
	4	CCV55069	Fitting / Hose Kits
	Customer to provide connection to air intake		

RACOR CCV™ APPLICATION BY ENGINE MANUFACTURER

CATERPILLAR (continued)

Marine Applications

ENGINE MODEL NO.	QTY.	P/N	DESCRIPTION
3208 (2 breathers)	1	CCV4500-08L (or R)	Filter Unit
	1	CCV55038	Fitting/ hose kit
	1	AF M408512	Marine Air Filter
3208 (High output)	1	CCV6000-08L (or R)	Filter Unit
	1	CCV55049	Fitting / Hose Kit
		Connect to CAT fitting on air intake	
3054, 3056 *	1	CCV4500-08L (or R)	Filter Unit
	1	CCV55024	Fitting / Hose Kit
	1	AF M408512	Marine Air Filter
3116, 3304, 3306 3126	1	CCV4500-08L (or R)	Filter Unit
	1	CCV55037	Fitting / Hose Kit
	1	AF M408512	Marine Air Filter
3406, D343 3176/3196	1	CCV6000-08L (or R)	Filter Unit
	1	CCV55046	Fitting / Hose Kit
	1	AF M601212	Marine Air Filter
3408 - single turbo	1	CCV6000-08L (or R)	Filter Unit
	1	CCV55047	Fitting/hose kit
	1	AF M601212	Marine Air Filter
3408 - twin turbo	1	CCV6000-08L	Filter Unit
3412 (2 breathers)	1	CCV6000-08R	Filter Unit
	2	CCV55046	Fitting / Hose Kits
	2	AF M501012	Marine Air Filters
3412 (High output, 4 breathers)	1	CCV6000-08L	Filter Unit
	1	CCV6000-08R	Filter Unit
	2	CCV55047	Fitting / Hose Kits
	2	AF M501012	Marine Air Filters
3508	1	CCV6000-08L	Filter Unit
D379, D398, D399	1	CCV6000-08R	Filter Unit
	2	CCV55049	Fitting / Hose Kits
		Customer to provide connection to air intake	
3512, 3516, 3606	1	CCV8000-08L	Filter Unit
D398, D399	1	CCV8000-08R	Filter Unit
	2	CCV55069	Fitting / Hose Kits
		Customer to provide connection to air intake	
3606	3	CCV8000-08L (or R)	Filter Units
	3	CCV55069	Fitting / Hose Kits
		Customer to provide connection to air intake	
3612, 3616	2	CCV8000-08L	Filter Units
	2	CCV8000-08R	Filter Units
	4	CCV55069	Fitting / Hose Kits
		Customer to provide connection to air intake	

* Remember to verify breather outlet and turbo inlet outside diameter sizes.

RACOR CCV™ APPLICATION BY ENGINE MANUFACTURER

CUMMINS

NOTE: On most engines, customer will need to provide bushings for hose kit installation to engine breathers. New 3/4" breather barb available from Cummins.

Industrial/Mobile Power Applications

ENGINE MODEL NO.	QTY.	P/N	DESCRIPTION
3A1.7, 4A2.1, 4B3.9, 4BT3.9	1	CCV4500-08L	Filter Unit
6B5.9, 6BT5.9, 6BTA5.9	1	CCV55024	Fitting / Hose Kit
6C8.3, 6CT8.3, 6CTA8.3	1	CCV30100	Tap Sleeve for 3" turbo
L10, V504, VT504, VT555		- OR -	
VTA555	1	CCV40100	Tap Sleeve for 4" turbo
KT19, KTA19, M11, N14	1	CCV6000-08L	Filter Unit
	1	CCV55046	Fitting / Hose Kit
	1	CCV50125	Tap Sleeve
V-903, VT-903	1	CCV6000-08L	Filter Unit
NTA-855, VTA-903	1	CCV55047	Fitting / Hose Kit
	1	CCV50125	Tap Sleeve
VTA28, KTA38	1	CCV6000-08R	Filter Unit
KTA38, KTA50**, KTTA50**	1	CCV6000-08L	Filter Unit
	2	CCV55046	Fitting / Hose Kits
	2	CCV60125	Tap Sleeves

Marine Applications

3A1.7, 4A2.1, 4B3.9, 4BT3.9	1	CCV4500-08L	Filter Unit
6B5.9, 6BT5.9, 6BTA5.9	1	CCV55024	Fitting / Hose Kit
6C8.3, 6CT8.3, 6CTA8.3	1	AF M408512	Marine Air Filter
V504, VT504, VT555, VTA555			
KT19, KTA19, M11, N14	1	CCV6000-08L	Filter Unit
	1	CCV55046	Fitting / Hose Kit
	1	AF M601212	Marine Air Filter
V-903, VT-903	1	CCV6000-08L	Filter Unit
NTA-855, VTA-903	1	CCV55047	Fitting / Hose Kit
	1	AF M501012	Marine Air Filter
VTA28, KTA38	1	CCV6000-08R	Filter Unit
KTA38	1	CCV6000-08L	Filter Unit
	2	CCV55046	Fitting / Hose Kits
	2	AF M501012	Marine Air Filters
KTA50**, KTTA50**	1	CCV6000-08R	Filter Unit
(Emergency/Intermittent Duty)	1	CCV6000-08L	Filter Unit
	2	CCV55046	Fitting / Hose Kits
	2	AF M601212	Marine Air Filters

** KTA50, KTTA50 - For Continuous Duty Engines:

	1	CCV8000-08L	Filter unit
	1	CCV8000-08R	Filter unit
	2	CCV55067	Fitting / Hose Kit
	2	CCV60125	Tap sleeves
		- OR -	
	2	AF M601212	Marine Air Filters

RACOR CCV™ APPLICATION BY ENGINE MANUFACTURER

DETROIT DIESEL

Industrial/Mobile Power Applications

ENGINE MODEL NO.	QTY.	P/N	DESCRIPTION
3-53, 4-53, 3-71*	1	CCV4500-08L (or R)	Filter Unit
Series 50	1	CCV55037	Fitting / Hose Kit
	1	CCV40100	Tap Sleeve
8.2 Liter	1	CCV4500-08L (or R)	Filter Unit
	1	CCV55038	Fitting / Hose Kit
	1	CCV40100	Tap Sleeve
4-71, 6-71, 6V71, 8V71*	1	CCV6000-08L (or R)	Filter Unit
6V92, 6V53, 8V92 up to 20 CFM	1	CCV55047	Fitting / Hose Kit
	1	CCV50125	Tap Sleeve
Series 60 / 11.2, 12.7 Liter	1	CCV6000-08L (or R)	Filter Unit
	1	CCV55046	Fitting / Hose Kit
	1	CCV50125	Tap Sleeve
8V92	1	CCV6000-08L	Filter Unit
12V71 *	1	CCV6000-08R	Filter Unit
	2	CCV55046	Fitting / Hose Kits
	2	CCV50125	Tap Sleeves
12V92, 16V92	1	CCV6000-08L	Filter Unit
	1	CCV6000-08R	Filter Unit
	2	CCV55047	Fitting / Hose Kit
	2	CCV50125	Tap Sleeves
12V149, 16V149 w/ 3 rocker cover breathers	1	CCV8000-08L	Filter Unit
	1	CCV8000-08R	Filter Unit
	1	CCV55067	Fitting / Hose Kit
	1	CCV55068	Fitting / Hose Kit
	2	CCV60125	Tap Sleeves
16V149, 20V149 High h/p engines w/ 4 rocker cover breathers	1	CCV8000-08L	Filter Unit
	1	CCV8000-08R	Filter Unit
	2	CCV55068	Fitting / Hose Kits
	2	CCV60125	Tap Sleeves

Marine Application

ENGINE MODEL NO.	QTY.	P/N	DESCRIPTION
3-53, 4-53, 3-71*	1	CCV4500-08L (or R)	Filter Unit
Series 50	1	CCV55037	Fitting / Hose Kit
	1	AF M408512	Marine Air Filter
8.2 Liter	1	CCV4500-08L (or R)	Filter Unit
	1	CCV55038	Fitting / Hose Kit
	1	AF M408512	Marine Air Filter
4-71, 6-71, 6V71, 8V71*	1	CCV6000-08L (or R)	Filter Unit
6V92, 6V53, 8V92 up to 600 hp (single turbo)	1	CCV55047	Fitting / Hose Kit
	1	AF M601212	Marine Air Filter *
		* twin turbo use (2) AF M501012, Marine Air Filters	
Series 60 / 11.2, 12.7 Liter	1	CCV6000-08L (or R)	Filter Unit
	1	CCV55046	Fitting / Hose Kit
	1	AF M501012	Marine Air Filter

* In all applications, please verify turbo inlet outside diameter size for correct application of tap sleeves.

RACOR CCV™ APPLICATION BY ENGINE MANUFACTURER

DETROIT DIESEL

Marine Application (continued)

ENGINE MODEL NO.	QTY.	P/N	DESCRIPTION
8V92	1	CCV6000-08L	Filter Unit
12V71 *	1	CCV6000-08R	Filter Unit
	2	CCV55046	Fitting / Hose Kits
	2	AF M501012	Marine Air Filters
12V92, 16V92	1	CCV6000-08L	Filter Unit
	1	CCV6000-08R	Filter Unit
	2	CCV55047	Fitting / Hose Kits
	2	AF M601212	Marine Air Filters
12V149, 16V149	1	CCV8000-08L	Filter Unit
with 3 rocker cover breathers	1	CCV8000-08R	Filter Unit
	1	CCV55067	Fitting / Hose Kit
	1	CCV55068	Fitting / Hose Kit
	2	AF M601212	Marine Air Filters
16V149, 20V149	1	CCV8000-08L	Filter Unit
High h/p engines w/ 4 rocker cover breathers	1	CCV8000-08R	Filter Unit
	2	CCV55068	Fitting / Hose Kits
	4	AF M601212	Marine Air Filters

HERCULES

Industrial/Mobile Power Applications

ENGINE MODEL NO.	QTY.	P/N	DESCRIPTION
G1600, 62300	1	CCV4500-08L (or R)	Filter Unit
	1	CCV55024	Fitting / Hose Kit
	1	CCV40100	Tap Sleeve
G3400, G4800	1	CCV4500-08L (or R)	Fitting Unit
D2300 Series, D3400 Series	1	CCV55025	Fitting / Hose Kit
D4800 Series	1	CCV40100	Tap Sleeve

VOLVO

Industrial/Mobile Power Applications

ENGINE MODEL NO.	QTY.	P/N	DESCRIPTION
All engine models with P/N 876069-0 breathers	1	CCV4500-08L (or R)	Filter Unit
Cartridge	1	CCV55037	Fitting / Hose Kit
	1	CCV40100	Tap Sleeve

Marine Applications

All engine models with P/N 876069-0 breathers	1	CCV4500-08L (or R)	Filter Unit
Cartridge less than 400 hp	1	CCV55037	Fitting / Hose Kit
	1	AF M408512	Marine Air Filter
Same as above except Over 400 hp	1	CCV6000-08L (or R)	Filter Unit
	1	CCV55046	Fitting / Hose Kit
	1	AF M501012	Marine Air Filter

* In all applications, please verify turbo inlet outside diameter size for correct application of tap sleeves.

RACOR CCV™ APPLICATION BY ENGINE MANUFACTURER

JOHN DEERE

Industrial/Mobile Power Applications

ENGINE MODEL NO.	QTY.	P/N	DESCRIPTION
Series 300/400	1	CCV4500R	Filter Unit
4039T, 4045T, 6059T	1	CCV55024	Fitting / Hose Kit
6059D, 6359A, 6068D	1	CCV40100	Tap Sleeve
6068T, 6076T, 6076A, 6076H			
Series 500	1	CCV4500R	Filter Unit
6619A	1	CCV55025	Fitting / Hose Kit
	1	CCV40100	Tap Sleeve

Marine Applications

Series 300/400	1	CCV4500R	Filter Unit
4039T, 4045T, 6059T	1	CCV55024	Fitting / Hose Kit
6059D, 6359A, 6068D	1	AF M408512	Marine Air Filter
6068T, 6076T, 6076A, 6076H			
Series 500	1	CCV4500R	Filter Unit
6619A	1	CCV55025	Fitting / Hose Kit
	1	AF M408512	Marine Air Filter

MACK

Industrial/Mobile Power Applications

ENGINE MODEL NO.	QTY.	P/N	DESCRIPTION
E6, E7, 37G, E9	1	CCV6000-08L (or R)	Filter Unit
	1	CCV55048	Fitting / Hose Kit
	1	CCV50125	Tap Sleeve

Marine Applications

E6, E7, 37G, E9	1	CCV6000-08L (or R)	Filter Unit
(up to 600 hp)	1	CCV55048	Fitting / Hose Kit
	1	* AF M501012	Marine Air Filter
		*Note: over 600 hp use AF M601212	
Same as above except	1	CCV8000-08L (or R)	Filter unit
Over 700 hp	1	CCV55067	Fitting / Hose Kit
	1	AF M601212	Marine Air Filter

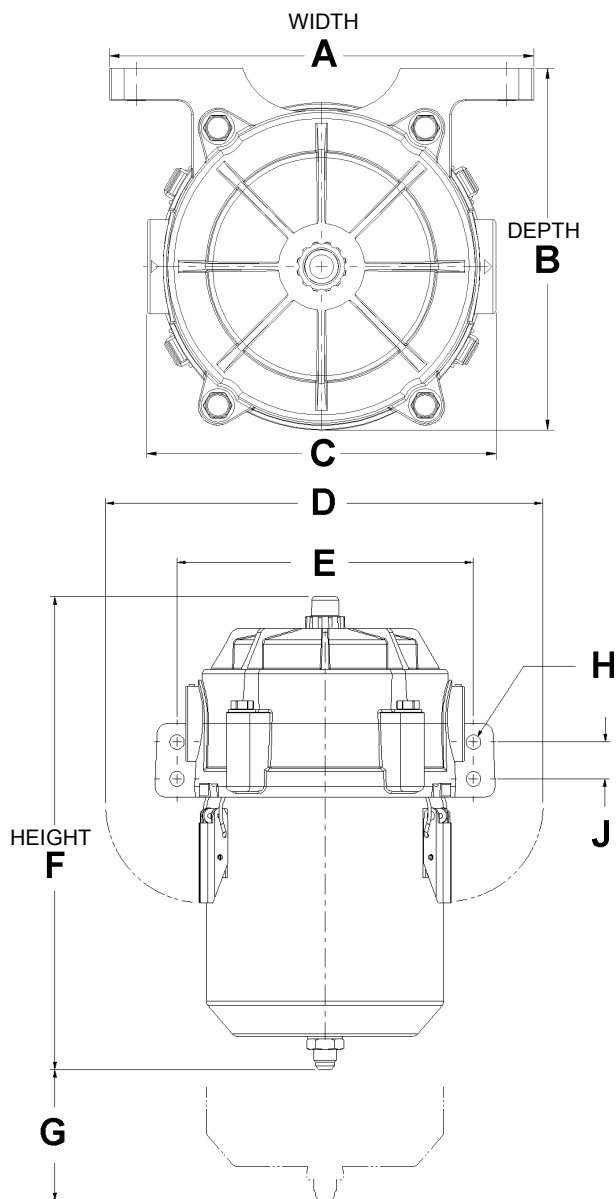

CCV6000-06L UNIT SHOWN

CCV™ DIMENSIONS

DIM	CCV4500		CCV6000		CCV8000	
	IN	MM	IN	MM	IN	MM
A	7.16	181.9	8.59	218.2	10.61	269.5
B	5.60	142.2	7.30	185.4	9.30	236.2
C	5.62	142.7	7.06	179.3	9.06	230.1
D	7.50	190.5	11.25	285.8	13.25	336.6
E	6.00	152.4	7.50	190.5	9.50	241.3
F	9.25	235.0	12.00	304.8	13.88	352.6
G	2.25	57.2	4.00	101.6	5.00	127.0
H	0.43	10.9	0.37	9.4	0.43	10.9
J	N/A	N/A	0.93	23.6	1.06	26.9

Dimension "G" is the minimum element removal clearance. Allow more room if possible for ease of service.

Dimension "J" is not applicable on CCV4500 units because there are only two (2) mounting holes. The CCV6000 and CCV8000 units have four (4) mounting holes.

CCV™ WEIGHTS

CCV4500		CCV6000		CCV8000	
LBS.	KG	LBS.	KG	LBS.	KG
3.26	1.48	5.01	2.28	8.72	3.96

Weights are dry, with element and fittings installed.

WARNING This product may contain a chemical known to the State of California to cause cancer. **WARNING** Failure or improper selection or improper use of the products and/or systems described herein or related items can cause death, personal injury, and property damage. This document and other information from Parker-Hannifin Corporation, its subsidiaries and authorized distributors provide product and/or system options for further investigation by users having technical expertise. It is important that you analyze all aspects of your application and review the information concerning the product or system in the current product catalog. Due to the variety of operation conditions and applications for these products or systems, the user, through its own analysis and testing, is solely responsible for making the final selection of the products and systems and assuring that all performance, safety and warning requirements of the applications are met. The products described herein, including with limitation, product features, specifications, designs, availability, and pricing are subject to change by Parker-Hannifin Corporation and its subsidiaries at any time without notice.

RACOR LIMITED WARRANTIES STATEMENT

All products manufactured or distributed by Racor are subject to the following, and only the following, LIMITED EXPRESS WARRANTIES, and no other. For a period of one (1) year from and after the date of purchase of a new Racor product, Racor warrants and guarantees only to the original purchaser-user that such a product shall be free from defects in material and workmanship in the manufacturing process. The warranty period for pumps and motors is specifically limited to ninety (90) days from date of purchase. A product claimed to be defective must be returned to the place of purchase. Racor, at its sole option, shall replace the defective product with a comparable new product or repair the defective product. This express warranty shall be inapplicable to any product not properly installed and properly used by the purchaser-user or to any product damaged or impaired by external forces.

THIS IS THE EXTENT OF WARRANTIES AVAILABLE ON THESE PRODUCTS. RACOR SHALL HAVE NO LIABILITY WHATSOEVER FOR CONSEQUENTIAL DAMAGES FLOWING FROM THE USE OF ANY DEFECTIVE PRODUCT OR BY REASON OF THE FAILURE OF ANY PRODUCT. RACOR SPECIFICALLY DISCLAIMS ALL OTHER WARRANTIES, EXPRESS OR IMPLIED INCLUDING, WITHOUT LIMITATION, ALL WARRANTIES OF FITNESS FOR A PARTICULAR PURPOSE (EXCEPT FOR THOSE WHICH APPLY TO PRODUCT OR PART THEREOF THAT IS USED OR BOUGHT FOR USE PRIMARILY FOR PERSONAL, FAMILY, OR HOUSEHOLD PURPOSES), WARRANTIES OF DESCRIPTION, WARRANTIES OF MERCHANTABILITY, TRADE USAGE OR WARRANTIES OR TRADE USAGE.